

操作手冊

三 聯 式 發 票 印 表 機

型號：WP-103S

WP-103

版本：1.03

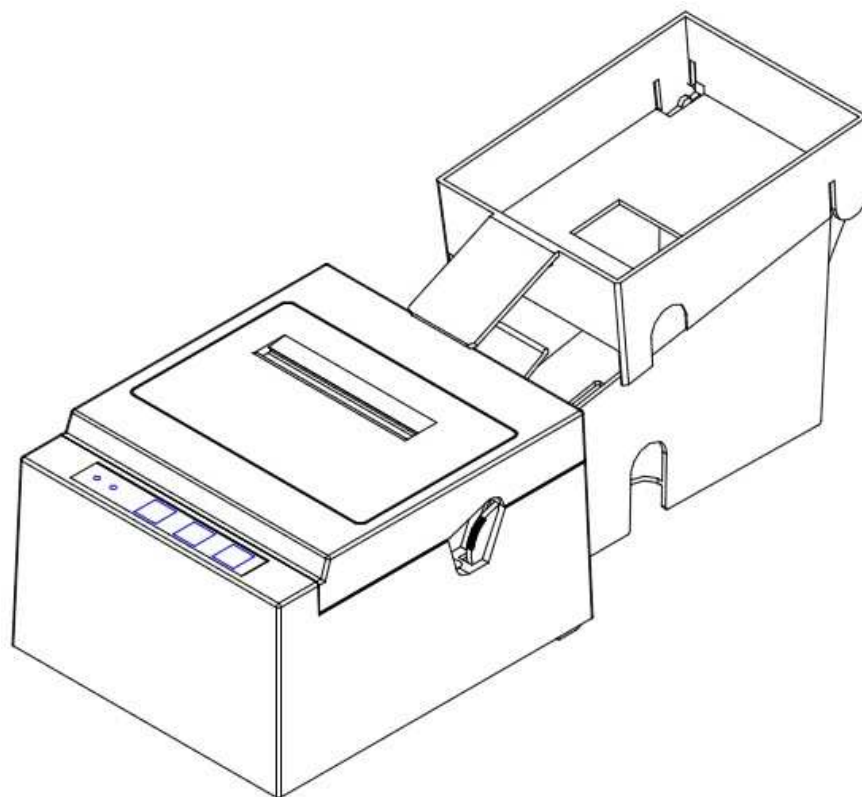

內 容

1. 功能規格	4
2. 拆箱檢視	5
2.1 檢視箱內部件	5
2.2 選擇使用位置	5
2.3 零組件名稱及功能	6
3. 安裝印表機	7
3.1 連接電源插頭到印表機	7
3.2 連接電腦主機到印表機	8
3.3 連接錢櫃到印表機	8
3.4 安裝色帶匣	9
3.5 安裝發票儲存槽	10
3.6 安裝發票紙	10
4. 鍵盤操作	11
4.1 鍵盤名稱及功能	11
4.2 印表機自我測試	12
5. 指撥開關的設定	13
6. 並列界面	15
6.1 一般規格	15
6.2 接腳編號及名稱	15
6.3 輸入/ 輸出訊號	16
6.4 時序圖	16
7. 串列界面	17
7.1 一般規格	17
7.2 接腳編號及名稱	17
7.3 輸入/ 輸出訊號	18
7.4 時序圖	18
8. 錢櫃之連結	19
8.1 一般規格	19
8.2 接腳編號及名稱	19
8.3 驅動電路	19
附錄 A. 印表機控制指令	20
A-1. 指令格式說明	20
A-2. Esc/pos 相容指令集	20
A-3. Star 相容指令集	31
附錄 B. 字元表	42

B-1. 中文字型碼	42
B-2. 國際字型.....	43
附錄 C. 外部尺寸	44

前言

WP-103 / WP-103S 是一款為台灣三聯式發票設計的高速撞針型印表機，此款印表機同時提供串列(RS-232C)及並列(Centronics)界面可輕易與電腦或系統主機連接，配合專為三聯式發票設計存放空白發票 250 份之儲存槽及已列印之存根聯儲存槽，大大改善了其他機種功能之不足，且紙張儲存槽、機體上蓋皆採透明處理，對於紙張之動態行徑一覽無遺，便於監視紙張於列印中之情況。

特性說明

- (1) 雙向高速列印，大約 3.6 行/秒。
- (2) 同時提供串列(RS-232C)及並列(Centronics)界面。
- (3) 可與顯示器共用同一界面(Pass through function)。
- (4) 內在緩衝儲存器擁有 4K bytes 記憶容量(約 20 張發票)，既使列印中也可接收資料。
- (5) 內含中文 13951 字，BIG-5 碼(特殊的 16x9 點狀中文字型或 16x16 點狀中文字型)。
- (6) 內含錢櫃界面。
- (7) 具『自動進紙及對位』功能。
- (8) 可偵測卡紙及發票用罄，並以燈號及聲響警示。
- (9) 可由指撥開關調整依循 Star 或是 EPSON Esc/pos 指令模式。
- (10) 具有分別存放空白發票 250 份之儲存槽及已列印之存根聯儲存槽。

1. 功能規格

項 目	內 容	
列印方式	串列式點矩陣撞擊	
針頭型式	9 針	
列印方向	橫式雙向	
列印速度	大約 3.6 行 / 秒	
字型數目	96 ASCII 字型和 13951 個中文字型以上	
行數	英數字 40 行，中文字 20 行	
字型構造	7 x 9(英數字字型)， WP-103S : 16 x 9 (中文字型) WP-103 : 16 x 16 (中文字型)	
進紙方式	帶孔進紙	
送紙間距	前進 4.23 mm(1/6 inch)，後退 0.705mm (4/144 inch)	
進紙速度	25 行/秒	
感應器	進紙就位感應器 錢櫃打開檢測	
紙張	形式:連續報表紙形式 寬度: 76 mm (3 inch) 厚度: 0.06 ~ 0.09 mm	
信賴度及壽命	機械 : MCBF 5 million lines 針頭 : 80 million character (approx. 200 million dot / pin)	
電源供應	24VDC/2.5A	
界面	串列(RS-232C)及並列(Centronics)	
錢櫃輸出	1	
工作環境	工作環境	溫度: 0 to 45°C; 濕度:10 to 90%RH; 假如溫度在 39°C 以上, 則濕度 相對的約在 85%。
	儲存環境	溫度: -10 to 50°C; 濕度: 10°C 90%RH for 96 小時.
外部尺寸	165mm(寬) x 195mm(深) x 112mm(高)	
總重量	大約 3.55kg	

2.1 型號說明

2. 拆箱檢視

2.1 檢視箱內部件

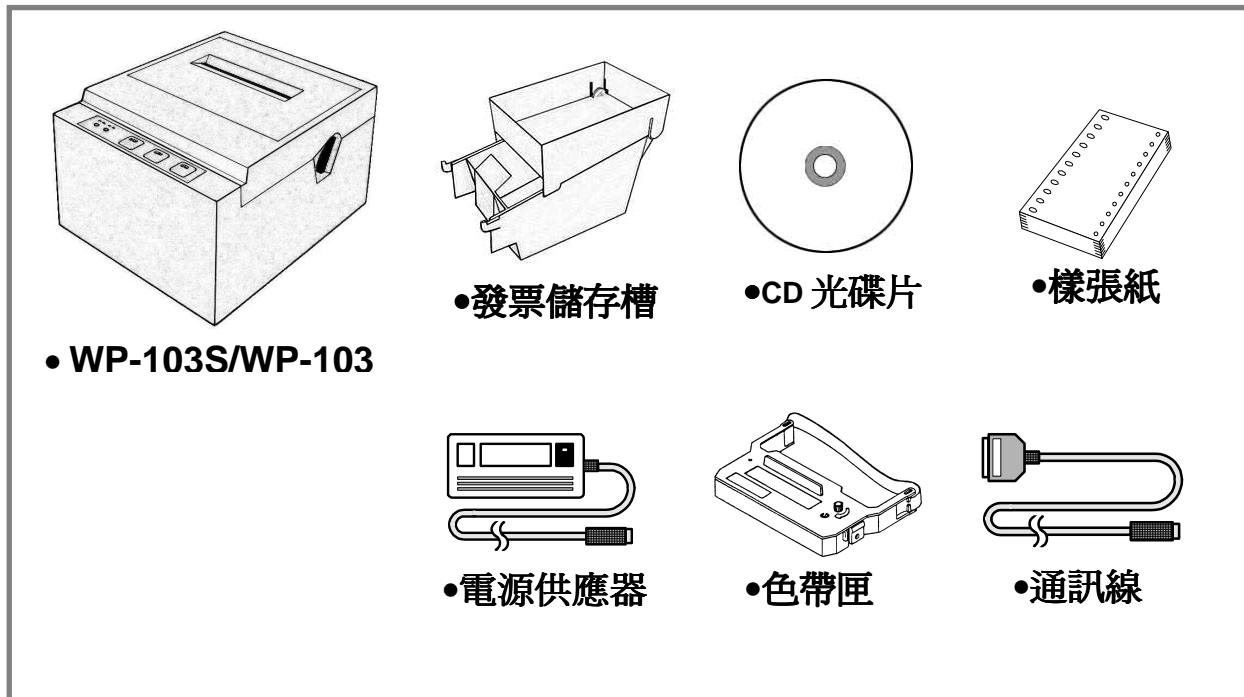

請確認沒有任何遺漏或短少的配件，如有發現任何疑問，請求供應商協助。

• 維修保養

保留外包裝盒萬一需要轉送或保存你的印表機。

2.2 選擇使用位置

- 避免放置於直接日曬或溫度過高處(靠近熱源)。
- 避免於溫度過高處或容易受潮處使用或放置該印表機。
- 不可在多粉塵或骯髒的場所使用或放置該印表機。
- 選擇一平穩處放置該印表機，劇烈的搖擺或振動可能會損害印表機。
- 確保該印表機有足夠的空間容易使用。

2.3 零組件名稱及功能

■ 部件說明

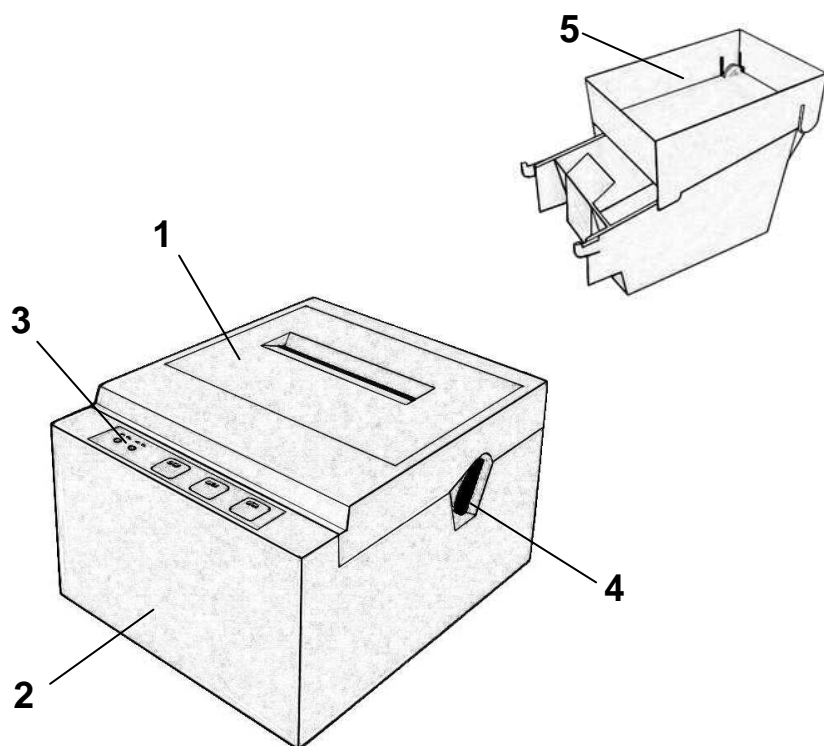

1. 上蓋。
2. 底座。
3. 操作鍵盤。
4. 手動進紙旋鈕。
5. 發票儲存槽。
6. 電源開關。
7. 串列界面。
8. 並列界面。
9. 錢櫃界面。
10. 電源接頭。

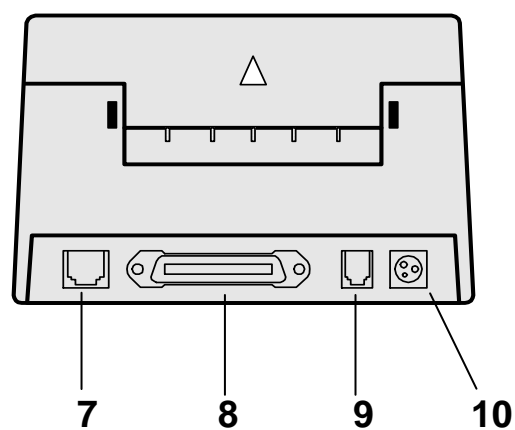
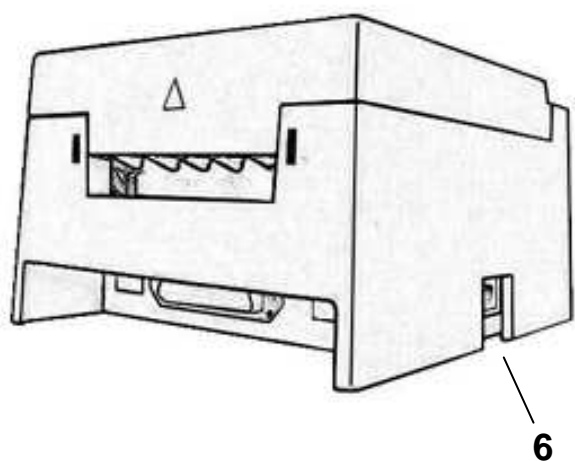

3. 安裝印表機

3.1 連接電源插頭到印表機

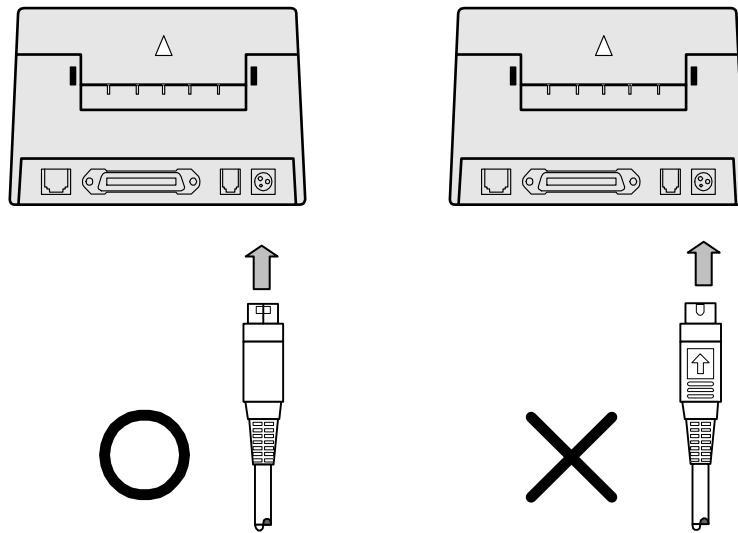

注意:

- 在連接到電源供應器之前，請確認電壓符合印表機的用電要求。
- 使用不正確的電源供應器會導致印表機嚴重的傷害。

■ **連接電源供應器(AC adapter) 請依照下列程序.**

- 確認印表機的電源開關是關閉的。
- 在將電源供應器接頭插入印表機插座時，請先確認電源供應器接頭上之箭頭符號朝下，如上圖示。
- 將插頭插上，並打開電源。

3.1.1 連接線的說明

接腳編號	接腳說明
1	+24VDC
2	邏輯地 (GND)
3	未定義 (NC)
Shell	外殼地 (Frame GND)

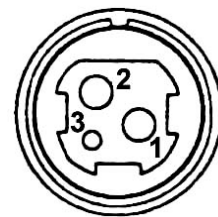

3.2 連接電腦主機到印表機

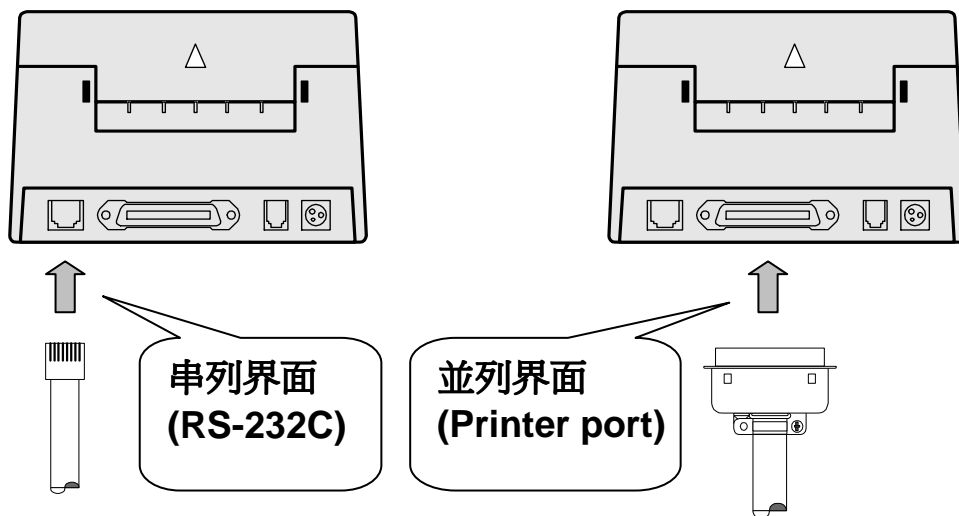

- 選擇串列界面(RS-232C)或是並列界面(Printer port)連接到你的電腦主機。
 1. 假如你選擇的是並列界面，你需要一個合適的並列通訊纜線連接至電腦。
 2. 假如你選擇的是串列界面，你可以使用我們的串列通訊線(連接線型式：電話接頭 10P8C/公)連接你的電腦到印表機(接頭型式：電話接頭 10P8C/母)。
 3. 確認印表機及電腦兩者的電源開關都是關閉的，然後牢固的插上通訊線至印表機。
 4. 將連接線的另一端插入電腦。

3.3 連接錢櫃到印表機

1. 確認印表機的電源是關閉。
2. 將錢櫃連接線牢固地插入印表機的插座內，如右圖，確定聽到‘喀’聲。

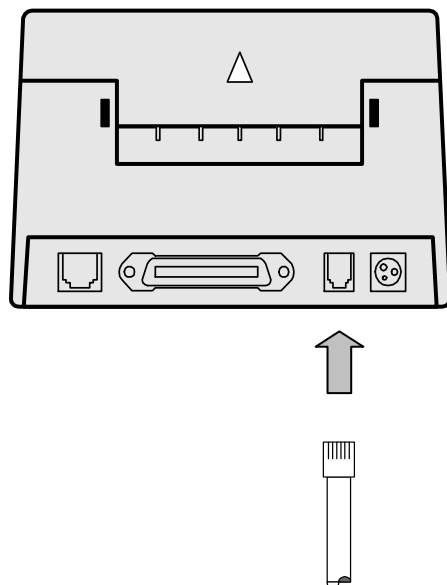

3.4 安裝色帶匣

使用 CITIZEN IR-61(P) 色帶匣。

注意：

請注意色帶匣上色帶旋轉的方向，請勿以反方向轉動旋鈕。

1. 打開電源開關並打開前蓋。
2. 依據箭頭的方向旋轉色帶匣的旋鈕 2 或 3 次，使色帶不致鬆弛。

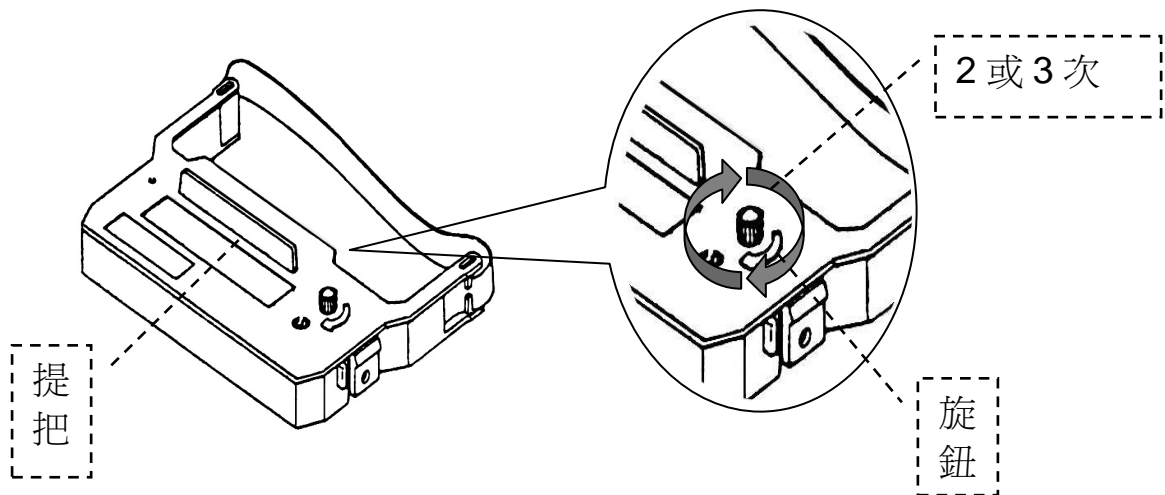

3. 將色帶匣放置於印表機印字頭與鐵片之中內如下圖所示，這是必要的步驟否則將使色帶匣壽命變短。

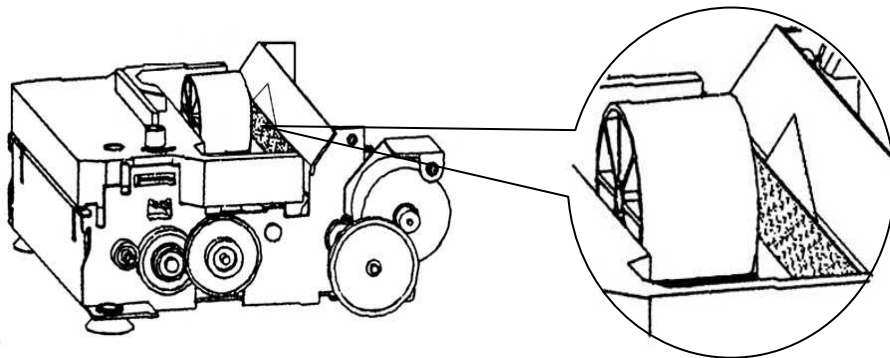

4. 色帶匣放置於印表機內完畢後，旋轉匣上的旋鈕 2 或 3 次如步驟 2.所示，這是必要的步驟，使色帶匣容易置於正確的位置。
5. 確認色帶平順的，沒有皺摺的被安裝於針頭前。
6. 假如色帶沒有安裝好，請按照上述步驟 2,3 和 4 再重裝一次。

注意：

在移除色帶匣時，緊抓著匣上的提把並拉出、提把位置如步驟 2 圖示。

3.5 安裝發票儲存槽

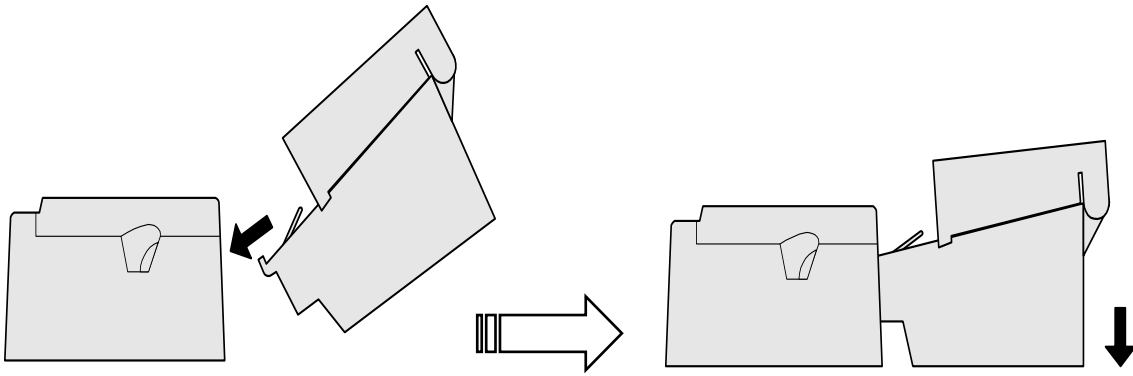

1. 將發票儲存槽前端之卡勾對準印表機本體背面之長方形缺口斜插進去，如圖所示。
2. 將發票儲存槽輕輕放下來即可，如圖 所示。

3.6 安裝發票紙

1. 使用的三聯式發票紙規格，請依照財政部規定之標準發票紙張。
2. 打開發票儲存槽上槽，確認三聯式空白發票紙的邊緣是平直的而且整齊的被置放在發票儲存槽下槽，如右圖所示。
3. 打開電源開關。
4. 將發票紙放入印表機內之紙張導槽。
5. 裝紙方式有兩種如下：

手動裝紙

- 1). 旋轉印表機右側缺口之齒輪，以目視配合手指旋轉至定位，旋轉方向如右圖所示。

自動裝紙(操作印表機上的鍵盤)

- 1). 將紙張裝入機心同時按下鍵盤上的 **進紙鍵**，直到印表機送紙凸輪確實帶動發票紙即可，但此時**紙張**指示燈仍必須保持恆亮的狀態。
- 2). 再按 **自動進紙鍵** 印表機將自動帶紙到出口定位。

6. 蓋上發票儲存槽上槽，再將已列印之發票存根聯回收至發票儲存槽上槽。

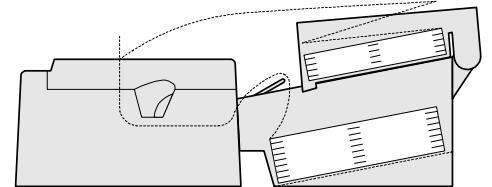
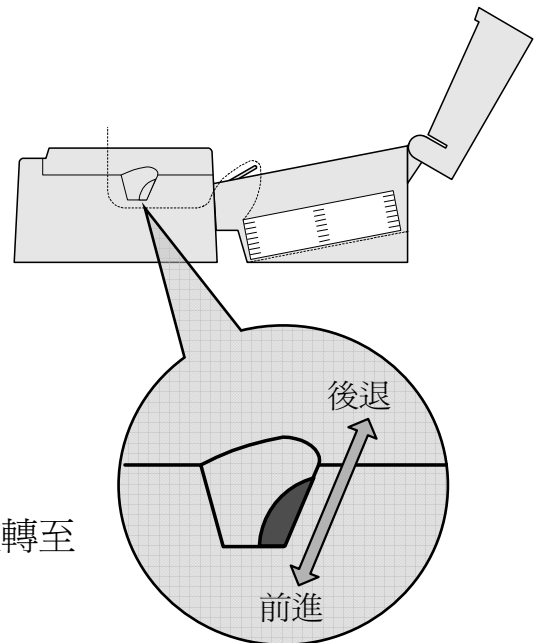

4. 鍵盤操作

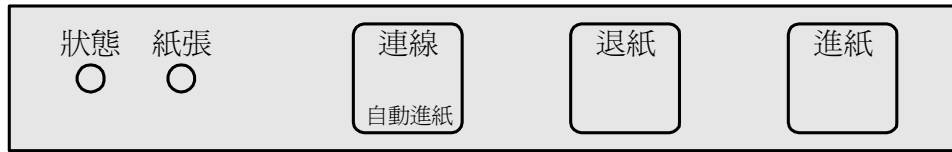

4.1 鍵盤名稱及功能

(1) 連線/自動進紙鍵 (On Line/Auto Feed)

- 1). 當發票紙沒紙或機械發生故障，印表機自動進入離線狀態，當問題被解決後，按此鍵恢復連線。
- 2). 當紙張用罄的錯誤發生時，按此鍵會自動將發票紙調整至出口定位。

(2) 退紙鍵 (Reverse Feed)

- 1). 按此鍵一次後退紙張 4/144 吋，若持續按著此鍵則連續後退。
- 2). 按此鍵可微調紙張出口之位置。

(3) 進紙鍵 (Forward Feed)

按此鍵一次送一行 1/6 吋，若持續按著此鍵則連續送行。

(4) 指示燈：鍵盤指示燈顯示印表機目前狀況。

狀態顯示(Status) (綠)

狀況	訊息	狀況	訊息
恆亮	連線	閃燈	故障或測試

當印表機機械發生故障或發票紙張用罄時，除指示燈顯示狀況外印表機會產生『嗶』聲警示，警示方式如下：

錯誤狀況	『嗶』聲警示訊息
印表機卡紙	短『嗶』聲，5 聲
紙張用罄	長『嗶』聲，3 聲

紙張顯示 (Paper end) (紅)

狀況	訊息	狀況	訊息
恆亮	紙張用罄	燈滅	有紙

4.2 印表機自我測試

(1) 一般規格測試〔開機 + **進紙鍵**〕

- 1). 當按 **進紙鍵** 後開機印表機會產生一個短『嗶』聲，此時印表機自動進入『一般規格』測試狀態並且列印出一張紙內容含機器型號、程式版本、紙撥開關設定、介面規格及字形。
- 2). 列印完畢後印表機將自動停止。
- 3). 若欲再列印一張，請再按 **進紙鍵** 一次。

(2) 介面通訊資料測試〔開機 + **連線鍵**〕

- 1). 當按 **連線鍵** 後開機印表機會產生一個短『嗶』聲，此時印表機自動進入『介面通訊資料』測試狀態。
- 2). 由電腦主機送至印表機之資料或命令將以 16 進制對應 ASCII 碼的方式列印出，電腦主機每送滿 8 字元〔Bytes〕之資料或命令，印表機將自動列印出一行。
- 3). 若欲列印出未滿 8 字元〔Bytes〕之資料或命令，請再按 **連線鍵** 一次，印表機會立即將資料或命令列印出。

(3) 結束測試〔關機後開機〕

若欲結束上述之測試，請關機後開機回復正常操作。

5. 指撥開關的設定

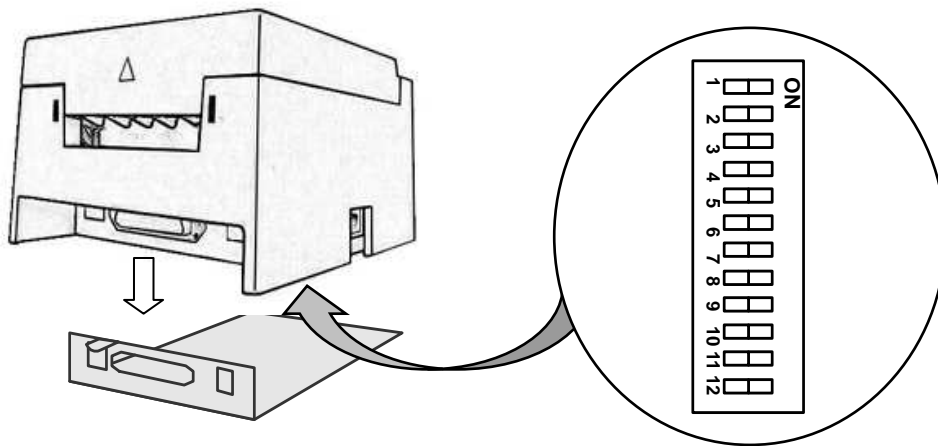

指撥開關之位置如下圖：

- 1). 在變更設定任何指撥開關前，請確定印表機開關已關閉電源。
- 2). 用十字螺絲起子卸下底部鐵板，即可看見控制板上之指撥開關，再依下列規格設定。

5-1 設定傳輸速率

DIP1-1	DIP1-2	傳輸速率
OFF	OFF	4800 bps.
ON	OFF	9600 bps.
OFF	ON	19200 bps.
ON	ON	38400 bps.

5-2 設定使用 STAR WINDOWS 驅動程式

DIP1-4	Star 驅動程式相容
OFF	不使用 Star 驅動程式
ON	使用 Star 驅動程式

注意：使用 STAR WINDOWS 驅動程式時，除了調整此指撥開關外、另外仍須將 DIP 1-9 調整至 ON 模擬 STAR 指令。

5-3 設定使用 EPSON FX-80 WINDOWS 驅動程式

DIP1-5	FX-80 驅動程式相容
OFF	不使用 FX-80 驅動程式
ON	使用 FX-80 驅動程式

注意：使用 FX-80 WINDOWS 驅動程式時，使用者可自行在 WINDOWS 內含印表機驅動程式庫內新增，但須自訂紙張規格如下：寬 8CM，高 14CM，上 0.51CM，下 3CM，左 0.8CM，右 0.48CM，其餘 0CM。

5-4 選擇印表頭出針力道

DIP1-7	DIP1-8	力道
OFF	OFF	特輕
OFF	ON	輕
ON	OFF	重
ON	ON	特重

5-5 設定指令

DIP1-9	指令
OFF	EPSON 相容指令
ON	Star 相容指令

5-6 設定切刀

DIP1-10	切刀
OFF	不含切刀
ON	含切刀

注意：此功能由工廠設定。

5-7 設定每行列印字數

DIP1-11	設定每行列印字數
OFF	英數字 40 字，中文 20 字
ON	英數字 36 字，中文 18 字

5-8 設定中文列印模式

DIP1-12	中文列印模式
OFF	單向列印
ON	雙向列印

6. 並列界面

6.1 一般規格

資料輸入方式 : 8 位元並列資料(DATA 1-8)
 控制訊號 : ACK-,BUSY, STB-, FAULT-, PE, RESET-
 線材規格 : DB25 – DB36 標準印表機連接線

6.2 接腳編號及名稱

編號	訊號名稱	編號	訊號名稱
1	STROB-	19	GND
2	DATA 1	20	GND
3	DATA 2	21	GND
4	DATA 3	22	GND
5	DATA 4	23	GND
6	DATA 5	24	GND
7	DATA 6	25	GND
8	DATA 7	26	GND
9	DATA 8	27	GND
10	ACK-	28	GND
11	BUSY	29	GND
12	PE	30	GND
13	SELECT	31	RESET-(INIT-)
14		32	FAULT-(ERROR-)
15		33	GND
16	GND	34	
17	F.G.	35	
18		36	SELECTIN

6.3 輸入/輸出訊號

(1) 印表機之輸入訊號

- DATA : 8 位元並聯訊號(正邏輯)。
- STB- : 讀取 8 位元資料之觸動信號(負邏輯)。
- RESET- : 重置印表機 (負邏輯)。

(2) 印表機之輸出訊號

- ACK- : 這個訊號在“BUSY”由高電位轉低電位之後產生(負邏輯)。
- BUSY : 這個訊號指示印表機處於忙碌狀態，新資料之輸入必須在此訊號為低電位狀態(正邏輯)。
- FAULT- : 當此訊號為低電位狀態時，表示印表機發生錯誤(負邏輯)。
- PE : 當此訊號為高電位狀態時，表示印表機發票紙之黑點定位錯誤(正邏輯)。

6.4 時序圖

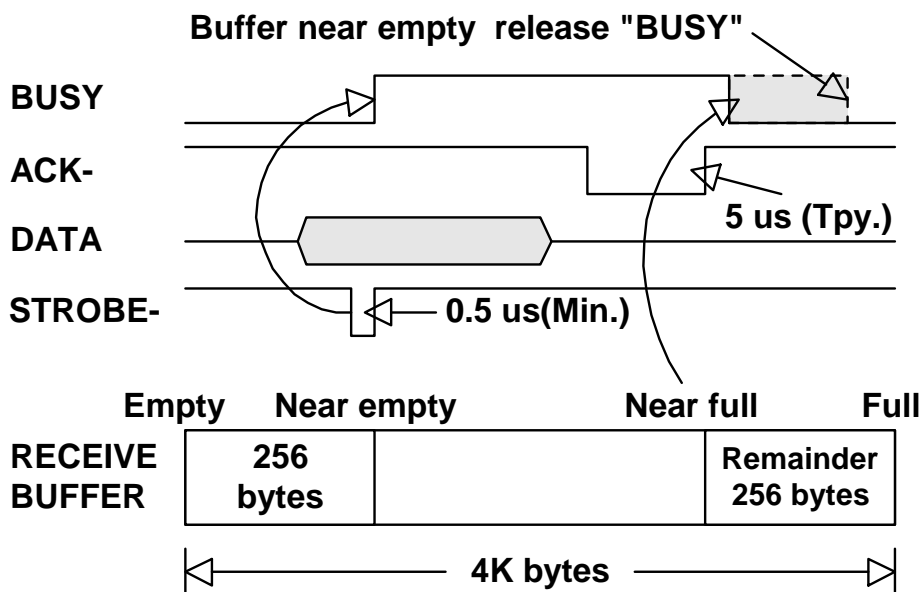

7. 串列界面

7.1 一般規格

(1) 資料轉換系統: 非同步序列資料

(2) 傳輸速率: 4800, 9600, 19200, 38400 bps (由指撥開關設定).

(3) 字元長度

Start bit : 1 bit
 Data bit : 8 bits (Fixed)
 Parity bit : No parity (Fixed)
 Stop bit : 1 bit or more

(4) 訊號屬性

- Mark = Logic "1" (-3V to -12V)
- Space = Logic "0" (+3V to +12V)

(5) 接收資料

- Mark = "1"
- Space = "0"

(6) 資料接收控制線 (DTR signal)

- Mark = Data transfer not possible
- Space = Data transfer possible

7.2 接腳編號及明稱

編號	訊號名稱	輸出/入	說明
1	VPP	輸出	+24VDC 電源輸出
2	VPP	輸出	
3	GND	-	邏輯地
4	GND	-	邏輯地
5	DTR	輸出	印表機忙碌信訊號
6	DSR	輸入	資料備妥
7	TXD	輸出	傳送資料線
8	RXD	輸入	接收資料線

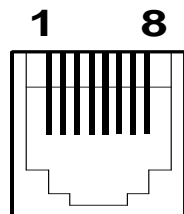

7.3 輸入/輸出訊號

(1) RXD

這是接收串列資料的訊號。

(2) DTR

當這個訊號出現時表示終端準備接受資料或指令。

假設資料在印表機忙碌時輸入，則資料將被接收到緩衝器直到緩衝器已滿。

“BUSY”訊號也同時發生在開啓電源、測試列印、沒紙、緩衝器欲滿或是印表機機械錯誤。

(3) TXD

當傳送印表機的狀況訊息時，這些資料將傳送而不理會“DSR”。

(4) GND

邏輯地。

7.4 時序圖

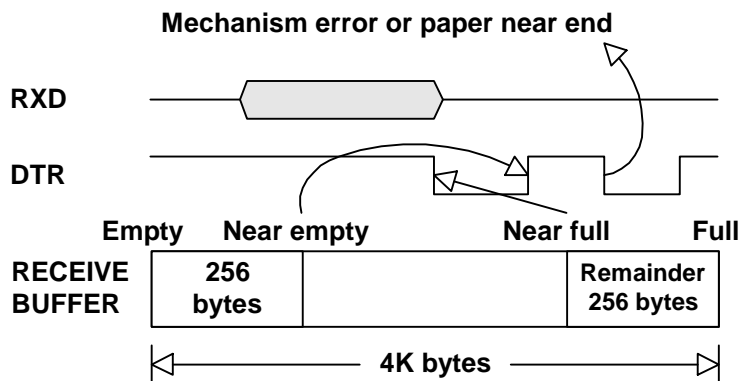

8. 錢櫃之連結

8.1 一般規格

(1) 資料轉換系統

訊號之輸出是由指令控制，主機可由指令返回之訊號得知錢櫃開或關的狀況。

(2) 電氣特性

1. 輸出電壓 : DC 24V
2. 輸出電流 : 0.8A at maximum (Should be within 510 ms)
3. 開關訊號 : Signal level "L" = 0 to 0.5V
"H" = 3 to 5V

8.2 接腳編號及名稱

編號	名稱	輸入/輸出
1	外殼地 (Frame GND)	-
2	錢櫃線圈	輸出
3	錢櫃開關輸入訊號	輸入
4	錢櫃線圈 [電源+24V]	輸出
5	未連接 (NC)	-
6	錢櫃開關輸入訊號 [邏輯地 GND]	輸入

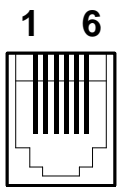

8.3 驅動電路

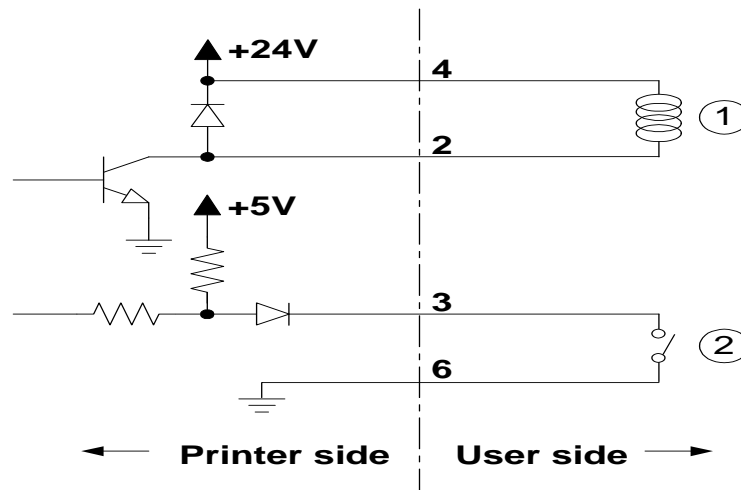

附錄 A. 印表機控制指令

A-1. 指令格式說明

COMMAND

[Name]	Command name.
[Format]	<>H indicates hexadecimal, <> indicates decimal, []k indicates k times repeat to control code and frequency.
[Range]	Gives the allowable range for set argument and data.
[Description]	Explain command function.
[Complement]	Complement particular.
[Note]	Gives important information on the setting and used of printer command, if necessary.

A-2. ESC/POS 相容指令集

◎ 選用下表指令集，請再度確認指撥開關之設定是否正確。

Command	Code	Name and description
FF	<0C>H	Print and eject this sheet
LF	<0A>H	Print and line feed
ESC SP	<1B>H<20>H	Set character right-side spacing
ESC @	<1B>H<40>H	Initialize printer
ESC !	<1B>H<21>H	Set print mode
ESC *	<1B>H<2A>H	Set bit image mode
ESC 2	<1B>H<32>H	Set 1/6 inch line spacing
ESC 3	<1B>H<33>H	Set spacing using minimum units
ESC J	<1B>H<4A>H	Print and feed paper using minimum units
ESC R	<1B>H<52>H	Select international character set
ESC U	<1B>H<55>H	Enable/disable unidirectional print
ESC d	<1B>H<64>H	Print and feed paper <i>n</i> lines
ESC p	<1B>H<70>H	Generate pulse for output drawer
ESC u	<1B>H<74>H	Transmit peripheral device status
ESC v	<1B>H<74>H	Transmit paper status
ESC C	<1B>H<43>H	Set paper length with <i>n</i> lines
ESC C <0>	<1B>H<43>H<0>	Set paper length with <i>n</i> inches
ESC K	<1B>H<4B>H	Print and reverse feed paper by <i>n</i> /144 inch

WP-103/103S RECEIPT PRINTER

ESC e	<1B>H<65>H	Print and reverse feed paper <i>n</i> line
ESC x	<1B>H<78>H	Set print mode for Chinese character
ESC ~	<1B>H<7E>H	Set print mode for Chinese character
ESC i	<1B>H<69>H	Execute full cut
ESC m	<1B>H<6D>H	Execute partial cut

FF

[Name]	Printing and eject this sheet .
[Format]	<0C>H
[Description]	Printing the last data and feed paper to beginning of next page.
[Reference]	Esc C

LF

[Name]	Print and line feed
[Format]	<0A>H
[Description]	Prints the data of in the buffer and feeds one line based on the current line spacing. <ul style="list-style-type: none"> • Set the print starting position to the beginning of the line.
[Reference]	Esc 2, Esc 3

ESC SP *n*

[Name]	Setting of character right-side spacing.
[Format]	<1B>H<20>H< <i>n</i> >
[Range]	$0 \leq n \leq 31$
[Description]	Set character right spacing with half dot unit. <i>n</i> indicates number of dots, add up spacing amount of <i>n</i> dots share to right of character. Therefore the character width become to following table.
[Default]	$n = 0$

Table: The width (dot) is that character right spacing is set to *n* dots

Font	Normal	Double width
7x9	$9+n$	$(9+n) \times 2$
9x9	$11+n$	$(11+n) \times 2$
16x9	$18+n$	$(18+n) \times 2$

[Unit: dot]

ESC @

[Name]	Initialize printer
[Format]	<1B>H<40>H
[Description]	Clears the data in the printer buffer and resets the print mode (Default state).

ESC ! n

[Name] Set print mode
 [Format] <1B>H<21>H<n>
 [Range] $0 \leq n \leq 255$
 [Description] Set print mode.
 Each bit of n is used as follows.

Bit	Function	Value	
		0	1
0	Character font	9 x 9 font	7 x 9 font
1	Undefined		
2	Undefined		
3	Undefined		
4	Double-height mode	Canceled	Set
5	Double-width mode	Canceled	Set
6	Undefined		
7	Underline	Canceled	Set

[Note]

- Underlines can be printed for all characters, but not for the space skipped an **HT** and Chinese characters.
- When both double-height mode and double-width mode are set, quadruple-size characters are printed.

[Default] $n = 1$

ESC * m n1 n2 [d] n1 + 256 x n2

[Name] Set bit image mode
 [Format] <1B>H<2A>H<m><n1><n2>[<d>]n1 + 256 x n2
 [Range] $m = 0, 1$
 $0 \leq n2 \leq 1$
 $0 \leq n1 \leq 255$
 $0 \leq d \leq 255$

[Description] Sets the bit image mode using m and the number of dots using $n1$ and $n2$.

- Divide the number of dots to be printed by 256. The integer answer is $n2$ and the remainder is $n1$. Therefore, the number of dots in the horizontal direction is calculated as : $n1 + 256 \times n2$.
- If the bit image data input exceeds the number of dots to be printed on a line, the excess data is ignored.
- “ d ” indicates the bit image data. Set a corresponding bit to 1 to print a dot, otherwise set it to 0.

- The bit image modes selectable by m are as follows:

m	Vertical Direction	Horizontal Direction		
	Number of Vertical dots	Dot density	Horizontal Adjacent Dots	Total Number of Dots
0	8	Single density	Printable	180
1	8	Double density	Unprintable	360

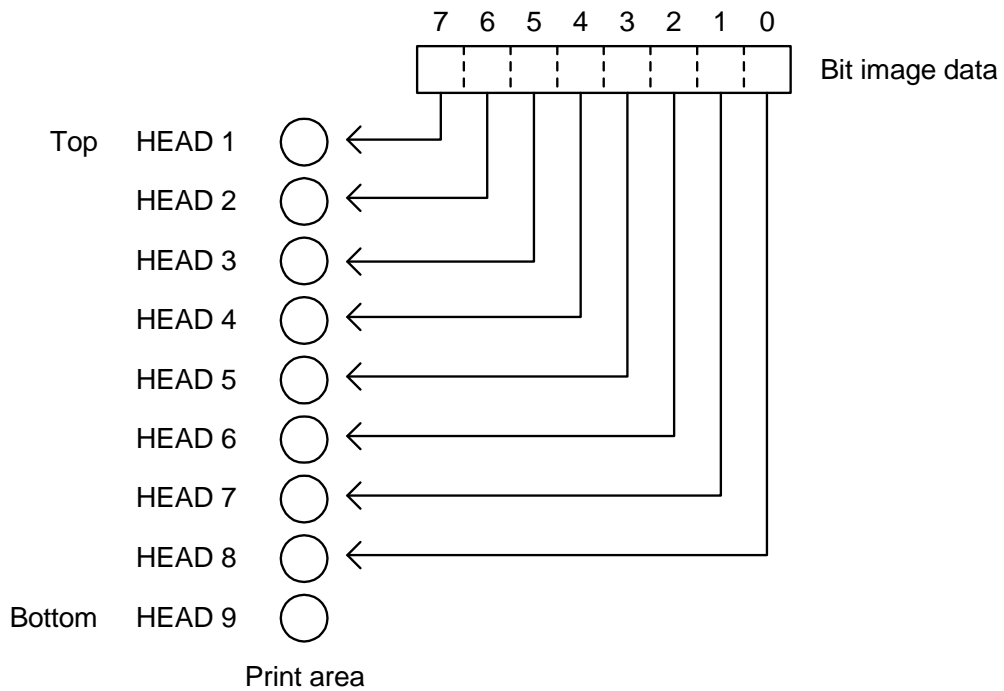

[Note]

- If m is out of range, the data following $n1$ (and the data including $n1$) is processed as normal data.
- After printing a bit image, the printer returns to normal data processing.
- The relationship between the image data and the dots to be printed is as follow:

ESC 2

[Name]	Set 1/6 inch line spacing
[Format]	<1B>H<32>H
[Description]	Set the line spacing to 1/6 of an inch.

ESC 3 *n*

[Name]	Set spacing using minimum units
[Format]	<1B>H<33>H< <i>n</i> >
[Description]	Set the line spacing to <i>n</i> /144 inches.
[Default]	<i>n</i> = 24 (1/6 of an inch)

ESC J *n*

[Name]	Print and feed paper using minimum units
[Format]	<1B>H<4A>H< <i>n</i> >
[Range]	$0 \leq n \leq 255$
[Description]	Prints one line of data from the print buffer and feeds the paper <i>n</i> /144 inches. <ul style="list-style-type: none"> • Set the print starting position to the beginning of the line. • The predetermined line spacing remains unchanged.

ESC R *n*

[Name]	Selection of international character set.
[Format]	<1B>H<52>H< <i>n</i> >
[Range]	$0 \leq n \leq 10$
[Description]	Select following country character by value of <i>n</i> .
[Default]	<i>n</i> = 0

Each bit of *n* is used as follows.

<i>n</i>	字型設定	<i>n</i>	字型設定	<i>n</i>	字型設定
0	美國	4	丹麥 I	8	日本
1	法國	5	瑞典	9	挪威
2	德國	6	義大利	10	丹麥 II
3	英國	7	西班牙		

ESC U n

[Name]	Enable / disable unidirectional print
[Format]	<1B>H<55>H<n>
[Range]	$0 \leq n \leq 255$
[Description]	Enable or disable unidirectional print, <i>n</i> is valid lowest-order bit. <i>n</i> as follows: When Bit 0 = 1, Enable unidirectional print. When Bit 0 = 0, Disable unidirectional print.
[Default]	<i>n</i> = 0

ESC d n

[Name]	Print and feed paper <i>n</i> line
[Format]	<1B>H<64>H<n>
[Range]	$0 \leq n \leq 255$
[Description]	Prints data in the print buffer and feed the paper <i>n</i> line.

ESC p m n1 n2

[Name]	Generate drawer kick-out drive pulse
[Format]	<1B>H<70>H<m><n1><n2>
[Range]	<i>m</i> = 0 $0 \leq n1 \leq 255$ $0 \leq n2 \leq 255$
[Description]	The defined pulse, On time is <i>n1</i> X 2 ms, Off time is <i>n2</i> X 2 ms.
[Note]	Please don't execute "generate pulse" successively because of it is possible to causes over heat of drawer solenoid. Please use designated standard solenoid.
[Reference]	Chapter 9

ESC u n

[Name] Transmit peripheral device status
 [Format] <1B>H<75>H<n>
 [Range] n = 0,<30>H
 [Description] Transmit the current status of connector pin n.
 [Note] Transmitted status as following table.

Bit	Function	Value	
		0	1
0	Pin 3 level	“LOW”	“HIGH”
1	Undefined		
2	Undefined		
3	Not used	Fixed to “1”	-
4	Not used	Fixed to “1”	-
5	Undefined		
6	Undefined		
7	Undefined		

- When the connector is not used, the value of bit 0 is always “1”.
- The printer transmits only 1 byte without confirming that the host is ready to receive data (DSR).
- There may be a time lag between receiving this command and transmitting the status, so the user should be aware of this.

[Reference] Chapter 9

ESC v

[Name]	Transmit printer status
[Format]	<1B>H<76>H
[Description]	Transmit the current printer status.
[Note]	Transmitted status as following table.

Bit	Function	Value	
		0	1
0	Paper end	Paper present	Paper end
1	Undefined		
2	Undefined		
3	Not used	Fixed to "1"	-
4	Not used	Fixed to "1"	-
5	Undefined		
6	Undefined		
7	Undefined		

- The printer transmits only 1 byte without confirming that the host is ready to receive data (DSR).
- There may be a time lag between receiving this command and transmitting the status, so the user should be aware of this.

ESC C n

[Name]	Set page length at n lines
[Format]	<1B>H<43>H<n>
[Range]	$0 \leq n \leq 255$
[Description]	Set page length at n lines based on the current line spacing.
[Reference]	Esc 2, Esc 3
[Default]	$n = 33$

ESC C <0> n

[Name]	Set page length at n inches
[Format]	<1B>H<43>H<0>H<n>
[Range]	$0 \leq n \leq 127$
[Description]	Set page length at n inches.
[Default]	$n = 5.5$ inches

ESC K n

[Name]	Print and reverse feed paper by $n/144$ inch.
[Format]	<1B>H<4B>H<n>
[Range]	$0 \leq n \leq 255$
[Description]	Prints the data in the print buffer and feeds the paper by $n/144$ inch in the reverse direction. <ul style="list-style-type: none"> • Set the print starting position to the beginning of the line. • The predetermined line spacing remains unchanged.
[Default]	Not defined.

ESC e n

[Name]	Print and reverse feed paper n line
[Format]	<1B>H<65>H<n>
[Range]	$0 \leq n \leq 255$
[Description]	Prints data in the print buffer and feed the paper n lines in reverse direction.

ESC c 5 n

[Name]	Enable/disable panel switch
[Format]	<1B>H<63>H<35>H<n>
[Range]	$0 \leq n \leq 255$
[Description]	Enable or disable panel switch. <ul style="list-style-type: none"> • Only the lowest bit of n is valid. When Bit 0 = 1, Disable panel switch. When Bit 0 = 0, Enable panel switch. • If the panel switch is disabled by this command, the panel switch is unusable. Therefore, paper feeding using the FEED switch cannot be executed (except when the error of printer is occurring).
[Default]	$n = 0$

ESC x n

[Name]	Set print mode for Chinese character
[Format]	<1B>H<78>H<n>
[Range]	$n = <30>H, <31>H$
[Description]	Set print mode for Chinese character
[Note]	Each byte of n is used as follows.

Byte	Function
<30>H	Double-height Chinese character
<31>H	Normal Chinese character

ESC ~ n

[Name] Set print mode for Chinese character
 [Format] <1B>H<7E>H<n>
 [Range] $0 \leq n \leq 255$
 [Description] Set print mode for Chinese character
 Each bit of n is used as follows.

Bit	Function	Value	
		0	1
0	Double-height	Canceled	Set
1	Double-width	Canceled	Set
2	Single density	Canceled	Set
3	Bi-directional print	Canceled	Set
4	Undefined		
5	Undefined		
6	Undefined		
7	Undefined		

[Note] • When both double-height mode and double-width mode are set, quadruple-size characters are printed.

[Default] $n = <5>H$

ESC i

[Name] Execute full cut
 [Format] <1B>H<69>H
 [Description] Execute a full-cut of the paper
 [Note] • Valid only when input at the beginning of line.
 • This command is valid only when attaching mechanism with paper-cutter

ESC m

[Name] Execute partial cut
 [Format] <1B>H<6D>H
 [Description] Execute a partial-cut of the paper
 [Note] • Valid only when input at the beginning of line.
 • This command is valid only when attaching mechanism with paper-cutter

A-3. STAR 相容指令集

◎ 選用下表指令集，請再度確認指撥開關之設定是否正確。

Command	Code	Name and description
FF	<0C>H	Print and eject this sheet
LF	<0A>H	Print and line feed
CAN	<18>H	Clear data buffer and line buffer
Esc @	<1B>H<40>H	Initialize printer
ESC M	<1B>H<4D>H	Select font matrix 7x9
ESC P	<1B>H<50>H	Select font matrix 9x9
ESC :	<1B>H<3A>H	Select font matrix 9x9
SO	<0E>H	Set double-width character mode
DC4	<14>H	Cancel double-width character mode
ESC W	<1B>H<57>H	Set/cancel double-width character mode
ESC -	<1B>H<2D>H	Set/cancel underline mode
ESC z	<1B>H<7A>	Set 1/6 or 1/12 inch line spacing
ESC 0	<1B>H<30>H	Set 1/8 inch line spacing
ESC 3	<1B>H<33>H	Set line spacing by $n / 144$ inch
ESC a	<1B>H<61>H	Print and feed paper n lines
ESC C	<1B>H<43>H	Set paper length with n lines
ESC C <0>	<1B>H<43>H<0>	Set paper length with n inches
ESC K	<1B>H<4B>H	Set 8 dot single density bit image mode
ESC L	<1B>H<4C>H	Set 8 dot double density bit image mode
ESC J	<1B>H<4A>H	Print and feed paper by $n / 72$ inch
ESC h	<1B>H<68>H	Set/cancel double-height character mode
ESC BEL	<1B>H<07>H	Generate pulse for output drawer
BEL	<07>H	Output drawer 1
FS	<1C>H	Output drawer 1
SUB	<1A>H	Output drawer 1
EM	<19>H	Output drawer 1
ESC U	<1B>H<55>H	Enable/disable singleness direction print
RS	<1E>H	Generates a shot alarm

WP-103/103S RECEIPT PRINTER

ESC d	<1B>H<64>H	Drive auto-cutter
ESC R	<1B>H<52>H	Select international character set
ESC e	<1B>H<65>H	Enable/disable panel switch
ESC x	<1B>H<78>H	Set print mode for Chinese character
ESC ~	<1B>H<7E>H	Set print mode for Chinese character

FF

[Name]	Printing and eject this sheet .
[Format]	<0C>H
[Description]	Printing the last data and feed paper to beginning of next page,.
[Reference]	Esc C

LF

[Name]	Print and line feed
[Format]	<0A>H
[Description]	Prints the data of in the buffer and feeds one line based on the current line spacing. • Set the print starting position to the beginning of the line.
[Reference]	Esc 2, Esc 3

CAN

[Name]	Clear data buffer and line buffer
[Format]	<18>H
[Description]	Clears the data in the printer buffer and resets the print mode (Default state).

ESC @

[Name]	Initialize printer
[Format]	<1B>H<40>H
[Description]	Clears the data in the printer buffer and resets the print mode (Default state).

ESC M

[Name]	Select font matrix 7x9
[Format]	<1B>H<4D>H
[Description]	Select font matrix 7x9

ESC P

[Name]	Select font matrix 9x9
[Format]	<1B>H<50>H
[Description]	Select font matrix 9x9

ESC :

[Name]	Select font matrix 9x9
[Format]	<1B>H<3A>H
[Description]	Select font matrix 9x9

S0

[Name]	Set double-width character mode
[Format]	<0E>H
[Description]	Set double-width character mode
[Reference]	Esc W

DC4

[Name]	Cancel double-width character mode
[Format]	<14>H
[Description]	Cancel double-width character mode
[Reference]	Esc W

ESC W n

[Name]	Enable/disable double-width character mode
[Format]	<1B>H<57>H<n>
[Range]	$0 \leq n \leq 255$
[Description]	Enable or disable double-width character mode. <ul style="list-style-type: none"> • Only the lowest bit of n is valid. <ul style="list-style-type: none"> When Bit 0 = 1, Enable double-width character mode. When Bit 0 = 0, Disable double-width character mode.
[Default]	$n = 0$
[Reference]	SO, DC4

ESC - n

[Name]	Enable/disable underline character mode
[Format]	<1B>H<57>H<n>
[Range]	$0 \leq n \leq 255$
[Description]	Enable or disable underline character mode. <ul style="list-style-type: none"> • Only the lowest bit of n is valid. <ul style="list-style-type: none"> When Bit 0 = 1, Enable underline character mode. When Bit 0 = 0, Disable underline character mode.
[Default]	$n = 0$
[Reference]	SO, DC4

ESC z n

[Name]	Set 1/6 or 1/12 inch line spacing
[Format]	<1B>H<7A><n>
[Range]	$0 \leq n \leq 255$
[Description]	Set the line spacing to 1/6 or 1/12 of an inch. <ul style="list-style-type: none"> • Only the lowest bit of n is valid. When Bit 0 = 1, Set 1/6 inch line spacing. When Bit 0 = 0, Set 1/12 inch line spacing.
[Default]	$n = 1$

ESC 0

[Name]	Set 1/8 inch line spacing
[Format]	<1B>H<30>H
[Description]	Set the line spacing to 1/8 of an inch.

ESC y n

[Name]	Set line spacing by $n / 144$ inches.
[Format]	<1B>H<79>H<n>
[Description]	Set the line spacing to $n / 144$ inches.
[Default]	$n = 24$ (1/6 of an inch)

ESC a n

[Name]	Print and feed paper n line
[Format]	<1B>H<61>H<n>
[Range]	$0 \leq n \leq 255$
[Description]	Prints data in the print buffer and feeds the paper n line.

ESC C n

[Name]	Set page length at n lines
[Format]	<1B>H<43>H<n>
[Range]	$0 \leq n \leq 255$
[Description]	Set page length at n lines based on the current line spacing.
[Reference]	ESC z, ESC 0, ESC y
[Default]	$n = 33$

ESC C <0> n

[Name]	Set page length at n inches
[Format]	<1B>H<43>H<0>H<n>
[Range]	$0 \leq n \leq 127$
[Description]	Set page length at n inches.
[Default]	$n = 5.5$ inches

ESC K *n1 n2* [*d*] *n1*

[Name] Set 8 dot single density bit image mode

[Format] <1B>H<4B>H<*n1*><*n2*>[<*d*>]*n1*

[Range] *n2* = 0
 $0 \leq n1 \leq 200$
 $0 \leq d \leq 255$

[Description]

- Executes 8 dot single density bit image print determined by “*n1*”. The total number of bit image data bytes in one line is equal to *n1*(max. 180 dots).
- If the bit image data input exceeds the number of dots to be printed on a line, the excess data is ignored.
- “*d*” indicates the bit image data. Set a corresponding bit to 1 to print a dot, otherwise set it to 0.

[Note]

- If *n1* is out of range, the data following *n1* (and the data including *n1*) is processed as normal data.
- After printing a bit image, the printer returns to normal data processing.
- The relationship between the image data and the dots to be printed is as follow:

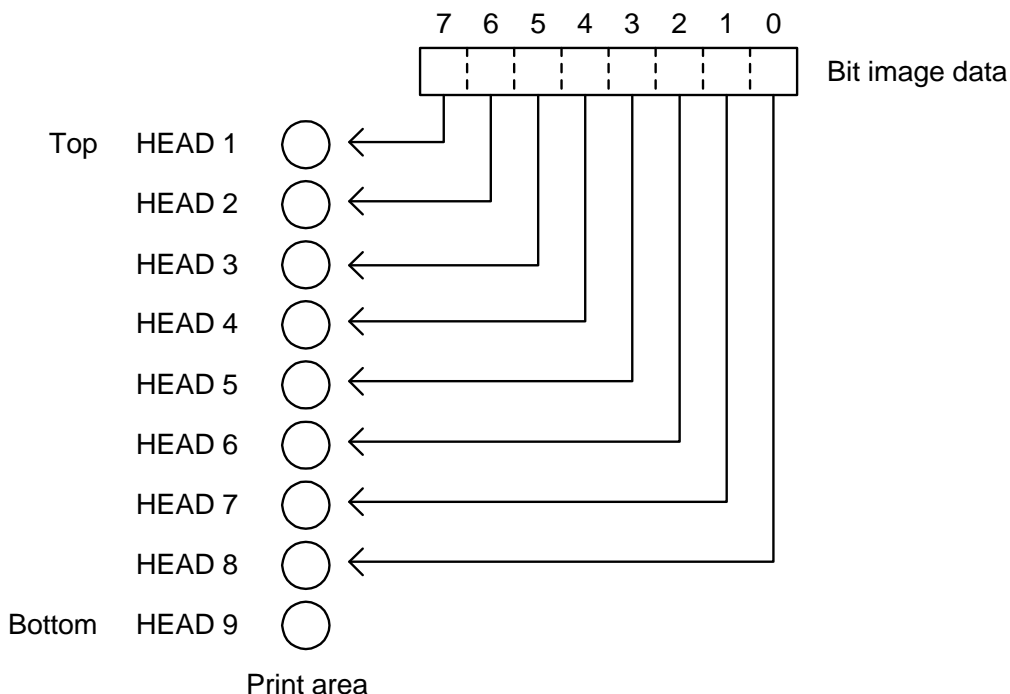

ESC L $n1$ $n2$ [d] $n1 + 256 \times n2$

[Name] Set 8 dot double density bit image mode
 [Format] <1B>H<4C>H< $n1$ >< $n2$ >[< d >] $n1 + 256 \times n2$
 [Range] $0 \leq n2 \leq 1$
 $0 \leq n1 \leq 255$
 $0 \leq d \leq 255$

[Description]

- Executes 8 dot double density bit image printing(half-dot printing) determined by “ $n1$ ” and “ $n2$ ”. The total number of bit image data bytes in one line is equal to $n1 + n2 \times 256$ (Max. 360 dots).
- If the bit image data input exceeds the number of dots to be printed on a line, the excess data is ignored.
- “ d ” indicates the bit image data. Set a corresponding bit to 1 to print a dot, otherwise set it to 0.

[Note]

- If $n1 + 256 \times n2$ is out of range, the data following $n1$ (and the data including $n1$) is processed as normal data.
- After printing a bit image, the printer returns to normal data processing.
- The relationship between the image data and the dots to be printed is as follow:

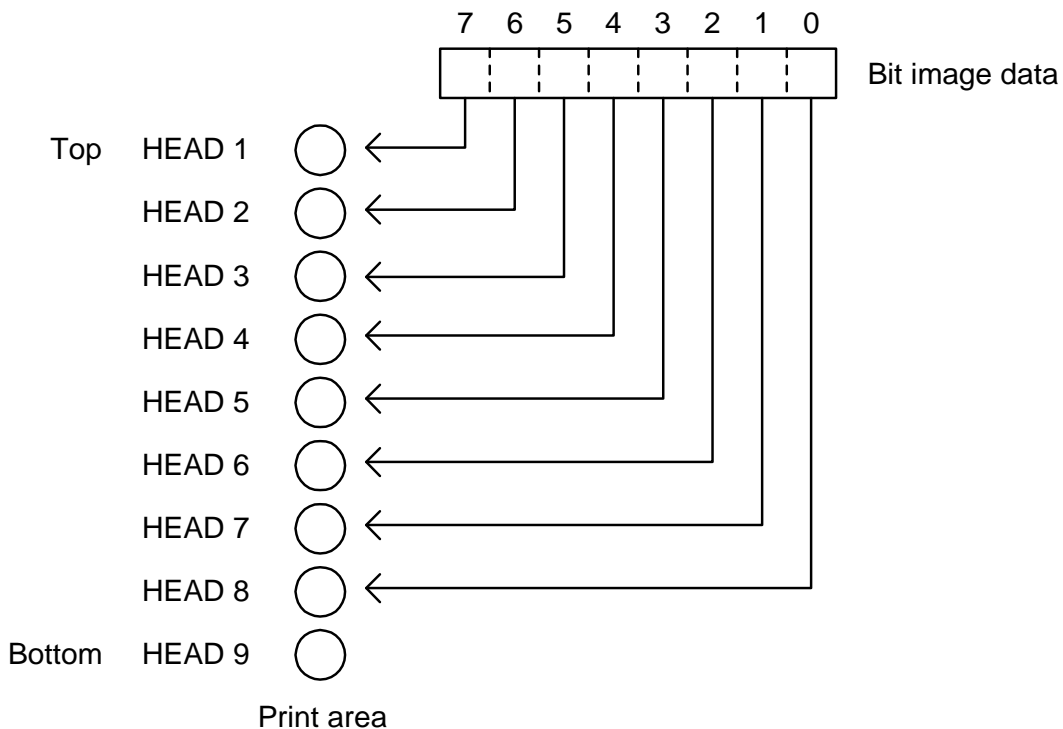

ESC J n

[Name]	Print and feed paper by $n / 72$ inch
[Format]	<1B>H<4A>H<n>
[Range]	$0 \leq n \leq 255$
[Description]	Prints one line of data from the print buffer and feeds the paper $n / 72$ inches. <ul style="list-style-type: none"> • Set the print starting position to the beginning of the line. • The predetermined line spacing remains unchanged.

ESC h n

[Name]	Enable/disable double-height character mode
[Format]	<1B>H<68>H<n>
[Range]	$0 \leq n \leq 255$
[Description]	Enable or disable double-height character mode. <ul style="list-style-type: none"> • Only the lowest bit of n is valid. When Bit 0 = 1, Enable double-height character mode. When Bit 0 = 0, Disable double-height character mode.
[Default]	$n = 0$

ESC BEL n1 n2

[Name]	Generate drawer kick-out drive pulse
[Format]	<1B>H<07>H<n1><n2>
[Range]	$0 \leq n1 \leq 127$ $0 \leq n2 \leq 127$
[Description]	The defined pulse, On time is $n1 \times 10$ ms, Off time is $n2 \times 10$ ms.
[Note]	Please don't execute "generate pulse" successively because of it is possible to causes over heat of drawer solenoid. Please use designated standard solenoid.
[Reference]	Chapter 9

BEL

[Name]	Output drawer at fixed pulse
[Format]	<07>H
[Description]	The defined pulse, On time is 200 ms, Off time is 200 ms.
[Note]	Please don't execute "generate pulse" successively because of it is possible to causes over heat of drawer solenoid. Please use designated standard solenoid.

FS

[Name]	Output drawer at fixed pulse
[Format]	<1C>H
[Description]	The defined pulse, On time is 200 ms, Off time is 200 ms.
[Note]	Please don't execute "generate pulse" successively because of it is possible to causes over heat of drawer solenoid. Please use designated standard solenoid.

SUB

[Name]	Output drawer at fixed pulse
[Format]	<1A>H
[Description]	The defined pulse, On time is 200 ms, Off time is 200 ms.
[Note]	Please don't execute "generate pulse" successively because of it is possible to causes over heat of drawer solenoid. Please use designated standard solenoid.

EM

[Name]	Output drawer at fixed pulse
[Format]	<19>H
[Description]	The defined pulse, On time is 200 ms, Off time is 200 ms.
[Note]	Please don't execute "generate pulse" successively because of it is possible to causes over heat of drawer solenoid. Please use designated standard solenoid.

ESC U n

[Name]	Enable / disable unidirectional print
[Format]	<1B>H<55>H<n>
[Range]	$0 \leq n \leq 255$
[Description]	Enable or disable unidirectional print, <i>n</i> is valid lowest-order bit. <i>n</i> as follows: Bit 0 = 1, Enable unidirectional print Bit 0 = 0, Disable unidirectional print
[Default]	<i>n</i> = 0

RS

[Name]	Sound buzzer
[Format]	<1E>H
[Description]	Generates a short alarm.

ESC d n

[Name]	Drive auto-cutter
[Format]	<1B>H<64>H<n>
[Range]	$0 \leq n \leq 255$
[Description]	<i>n</i> is valid lowest-order bit. <i>n</i> as follows: Bit 0 = 1, Drive the auto-cutter for partial cut. Bit 0 = 0, Drive the auto-cutter for full cut.
[Note]	This command is valid only when attaching mechanism with paper-cutter

ESC R n

[Name]	Selection of international character set.
[Format]	<1B>H<52>H<n>
[Range]	$0 \leq n \leq 10$
[Description]	Select following country character by value of <i>n</i> .
[Default]	$n = 0$ Each bit of <i>n</i> is used as follows.

<i>n</i>	字型設定
0	美國
1	法國
2	德國
3	英國

<i>n</i>	字型設定
4	丹麥 I
5	瑞典
6	義大利
7	西班牙

<i>n</i>	字型設定
8	日本
9	挪威
10	丹麥 II

ESC x n

[Name]	Set print mode for Chinese character
[Format]	<1B>H<78>H<n>
[Range]	$n = \langle 30 \rangle H, \langle 31 \rangle H$
[Description]	Set print mode for Chinese character
[Note]	Each byte of <i>n</i> is used as follows.

Byte	Function
<30>H	Double-height Chinese character
<31>H	Normal Chinese character

ESC ~ n

[Name] Set print mode for Chinese character
 [Format] <1B>H<7E>H<n>
 [Range] $0 \leq n \leq 255$
 [Description] Set print mode for Chinese character
 Each bit of n is used as follows.

Bit	Function	Value	
		0	1
0	Double-height	Canceled	Set
1	Double-width	Canceled	Set
2	Single density	Canceled	Set
3	Bi-directional print	Canceled	Set
4	Undefined		
5	Undefined		
6	Undefined		
7	Undefined		

[Note] • When both double-height mode and double-width mode are set, quadruple-size characters are printed.
 [Default] $n = <5>H$

ESC e n

[Name] Enable/disable panel switch
 [Format] <1B>H<65>H<n>
 [Range] $0 \leq n \leq 255$
 [Description] Enable or disable panel switch.
 • Only the lowest bit of n is valid.
 When Bit 0 = 1, Disable panel switch.
 When Bit 0 = 0, Enable panel switch.
 • If the panel switch is disabled by this command, the panel switch is unusable. Therefore, paper feeding using the FEED switch cannot be executed (except when the error of printer is occurring).
 [Default] $n = 0$

附錄 B. 字元表

B-1. 中文字型碼

	00	10	20	30	40	50	60	70	80	90	A0	B0	C0	D0	E0	F0
0	NUL	DLE	SP	0	@	P	`	P								
1			!	1	A	Q	A	Q								
2			“	2	B	R	B	R								
3			#	3	C	S	C	S								
4	EOT		\$	4	D	T	D	T								
5	ENQ		%	5	E	U	E	U								
6			&	6	F	V	F	V								
7			'	7	G	W	G	W								
8			(8	H	X	H	X								
9	HT)	9	I	Y	I	Y								
A	LF		*	:	J	Z	J	Z								
B		ESC	+	;	K	[K	{								
C			,	<	L	\	L									
D	CR	GS	-	=	M]	M	}								
E			.	>	N	^	N	~								
F		US	/	?	O	_	O	SP								

中文字元碼區域

B-2. 國際字型

國家	ASCII CODE												
	HEX	23	24	40	5B	5C	5D	5E	60	7B	7C	7D	7E
	DEC	35	36	64	91	92	93	94	96	123	124	125	126
美國	#	\$	@	[\]	^	`	{		}	~	
法國	#	\$	à	°	ç	§	^	`	é	ù	è	“	
德國	#	\$	§	Ä	Ö	Ü	^	`	ä	ö	ü	ß	
英國	£	\$	@	[\]	^	`	{		}	~	
丹麥 I	#	\$	@	Æ	Ø	Å	^	`	æ	f	å	~	
瑞典	#	☉	É	Ä	Ö	Å	Ü	é	ä	ö	å	ü	
義大利	#	\$	@	°	\	é	^	ù	à	ò	è	ì	
西班牙	PT	\$	@	i	Ñ	¿	^	`	“	ñ	}	~	
日本	#	\$	@	[¥]	^	`	{		}	~	
挪威	#	☉	É	Æ	Ø	Å	Ü	é	æ	f	å	ü	
丹麥 II	#	\$	É	Æ	Ø	Å	Ü	é	æ	f	å	ü	

附錄 C. 外部尺寸

